

Specification

Model	Unit	PT-103/104	PT-203/204
Power input		1-Phase 100~240VAC 50/60Hz	
Capacity(Horizontal/Vertical)	kg	100 / 60	200 / 130
Rated eccentricity	mm	A:180 B:90 C:60 D:45	A:84 B:42 C:28 D:10
Table dimension	mm	Ø320	
Rotation speed	rpm	A:0.3~4 B:0.6~8 C:0.8~12 D:1~16	
Through hole diameter	mm	Ø22	
Earthing	amp	300	
Tilt range	deg	0 ~ 120	
Welding timer	sec	0 ~ 60	
Dimension (A x B x C)	mm	460 x 315 x 340	
Center to floor (D)	mm	250	
Weight	kg	38	42

※ Specifications subject to change without notice.

Dimension

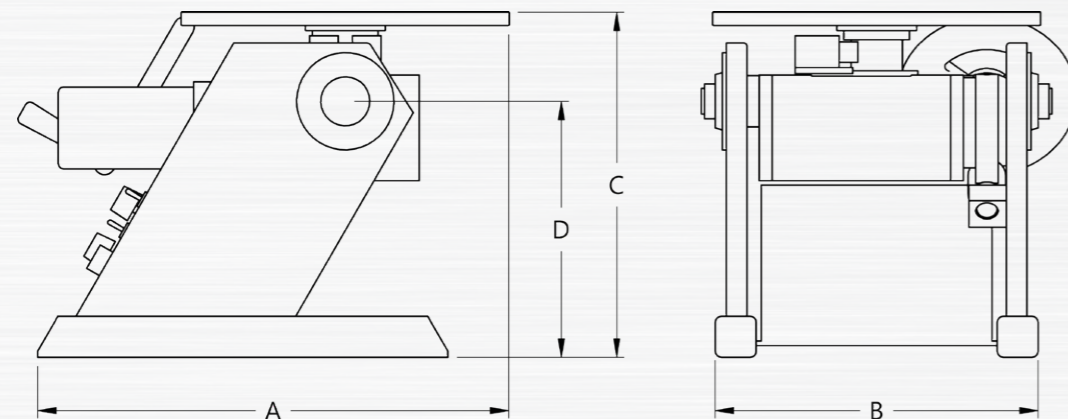

E.Z.ARC SYSTEM

Semi-automation welding package

Welding Automation

United ProArc Corporation

No.8 Gungye 2nd Road, Pingjen Industrial Park, Pingjen Dist., Taoyuan City 324403, Taiwan

Tel : 886-3-4696600 Fax : 886-3-4694499 E-mail : sales@proarc.com.tw

SD-4010DE

E.Z.Arc circumferential welding system

ProArc deliver the new generation E.Z.Arc circumferential welding system with the widest choice of components, we help customer to create your automatic welding system more easily and perform best welding quality.

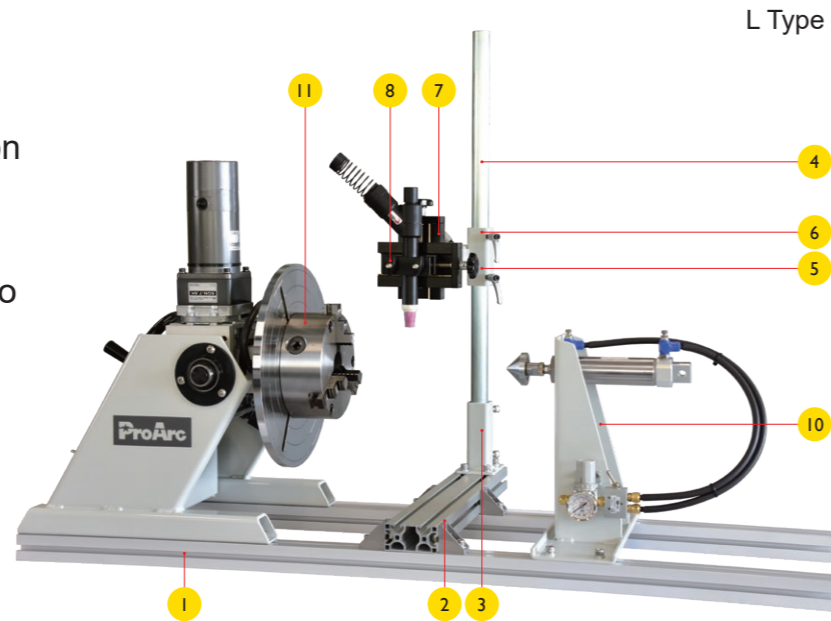

Fig. No.	Part No.	Description / Specification	S	R	L	U
1	1106	Base rail, 600 mm long	1 *			
	1112	Base rail, 1200 mm long		1 *	1 *	
	1115	Base rail, 1500 mm long				
	1118	Base rail, 1800 mm long				
2	4195	Main bracket				1
	2050	Mounting rail, 500 mm long	1	1	1	
3	2065	Mounting rail, 650 mm long				1
	2111	End bracket	1	1	1	
4	2281	End bracket				1
	3175	Column tube, 750 mm long	1	1	1	
5	3164	90° column tube, 600 mm x 400 mm				1
	2144	Cross bracket	1	1	1	1
6	3140	Boom tube with mounting pad, 400 mm long	1	1	1	1
	SL-050	Slide, 50 mm stroke (manual)	2	2	2	2
7	SL-075	Slide, 75 mm stroke (manual) - Option				
	AH-035	Any angle torch holder, Ø15-35 mm				
8	VH-035	V-Block torch holder, Ø15-35 mm	1	1	1	1
	IS-300	Idler stand, Ø30-300 mm		1		
9	TS-075	Tailstock, 75 mm stroke (pneumatic)			1	
	TS-075S	Tailstock, 75 mm stroke (pneumatic)				1

* The standard length of the type, other length available.

L Type

R Type

S Type

U Type

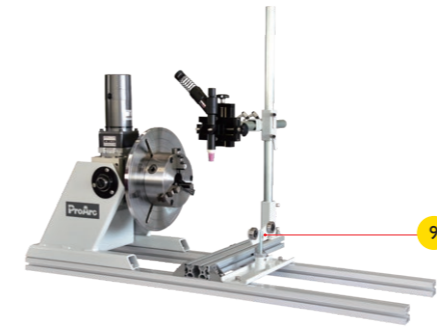

Options

Fig. No.	Part No.	Description / Specification
11	PG-150	3-Jaw chuck, OD 4 - 150 mm (option)
	PG-300	3-Jaw chuck, OD 4 - 300 mm (option)
12	TA-101	Pneumatic torch actuator
	TL-101	Pneumatic torch lift
13	CB-102	Sequencer, original sensor control
	CB-102D	Digital sequencer, original sensor control
14	CB-107	Smart controller, fully automated welding control
15	VSFC-1K	Variable speed foot control
16	TG-300	Tungsten Grinder Ø1.0 ~ 4.8 mm
		Fine diamond grinding wheel

Features

- Modern style and more compact design
- Advanced design PCB for new control box
- White base achromatic color suitable for any brand of welding power source
- High frequency protected
- Standard / digital type in 4 rotation speed available
- 2 year warranty
- CE Conformity

Fig. No.11



Fig. No.12

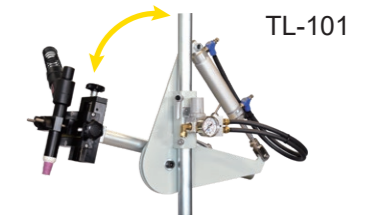
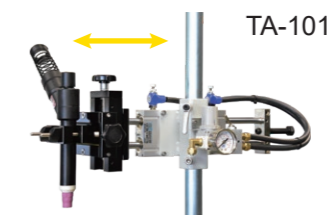

Fig. No.14



Smart controller

- Intuitive operating user interface
- Sequence timer
- 100 programs save/load
- Linear speed auto calculation
- User account control
- Alarm history

